

Van lift DH-P1.03

300 Kg



DHOLLANDIA



Step-in model, easy to use and flexible

The DH-P1 is a **single-arm lift**, suitable for mounting inside the rear or side doors of a wide range of factory built panel vans.

In its standard configuration, the DH-P1 has its travel position just inside the doors of the vehicle. As an option, it can be equipped with an **articulated frame** [option OWU006], that allows to stow the platform against the side of the body and keeps the access through the vehicles doors free.

The platform is **flat**, so that goods, such as roll-cages, white & brown goods, small machinery,..., can be loaded with minimal effort.

The DH-P1 can be mounted at the rear doors or at the side door; at the left or right side in the door aperture.



PLATFORM

- Flat platform with aluminium work surface
- Automatic roll-stop at the outboard platform edge
- Automatic bridge plate + toe-guard + load restraint at the inboard platform edge
- Mechanical platform lock, holding the platform in its travel position in case of accidental pressure loss

FUNCTIONAL & MECHANICAL CHARACTERISTICS

- 1 lift arm with 1 single-acting lift cylinder
- Standard: the platform is mounted on a fixed frame, the closed platform stands in the door aperture
- Optional: rotating frame [OWU006], the platform can be stowed away in a travel position against the side wall of the body
- Flat platform, level ride

HYDRAULICAL CHARACTERISTICS

- 12V or 24V DC pump unit premounted at the side of the lift frame

ELECTRICAL CHARACTERISTICS

- 2-button wander lead with spiral cable [OAE001]
- Main battery isolator switch premounted on the pump unit [OAE038]

FITTING

- Available for fitting on left side or on right side in the vehicle door aperture

FINISH & MAINTENANCE

- Low-maintenance bearings in all articulation points
- Intensive dampening of mechanical driving noises
- Lift frame in Protection PLUS finish (zinc phosphate + KTL epoxy primer + polyester powder top coat)

Disclaimer: data and images of lifts and options are indicative, and may vary in function of the lift execution and vehicle details. Ask confirmation from DHOLLANDIA.



TECHNICAL CHARACTERISTICS**DH-P1.03**

Lift frame	<ul style="list-style-type: none"> - 1 lift arm - Standard = fixed frame: the closed platform stands in the door aperture - Option OWU006 = articulated frame : the platform can be stowed in a travel position against the side of the body - Option OWU007 = fixed frame with a 1200 mm foldable platform
Cylinders	1 lift cylinder
Type of ride	Flat platform, level ride
Platform material	Steel frame + aluminium profiles
Platform equipment	<ul style="list-style-type: none"> - Automatic roll-stop at the outboard platform edge - Automatic bridge plate and toe-guard at the inboard platform edge
Standard platform depths	<ul style="list-style-type: none"> - 1080 - 1170 - 1260 mm standard - 1200 mm for OWU007 - Other depths on request [OWP002.L]
Standard platform widths	820 mm standard / 720 mm optional [OWP002.W]
Standard control unit	OAE001
Standard finish of the lift frame	Protection PLUS [OAT102]

MOUNTING DIMENSIONS**DH-P1.03**

larm	600	700
K max.	700	950





OAE001 - 2-button wander lead with spiral cable



OWE004 - Plug connection for wander lead on pump unit

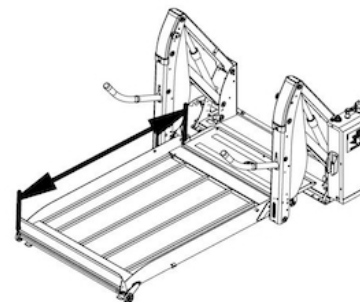

OWP002.L - Non-standard platform depth on DH-P

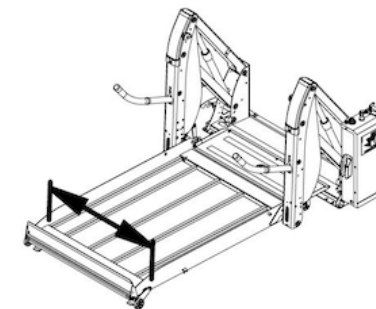

OWP002.W - Non-standard platform width on DH-P



OWP001 - Bridge plate mounted on inboard platform edge



OAT020 - Reflecting platform flags type TÜV



OAT023 - Reflecting platform flags type Export Red



OAT102 - Standard finish of lift frame: KTL + powder coat



OWU006 - Manually swivelling frame DH-P1/PH1

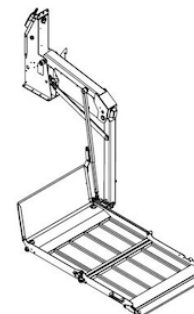

OWU007 - Horizontally folding platform DH-PH1

