

# Fold-away lift DH-RC.10

1000 Kg



**DHOLLANDIA**



## Light fold-away lift with level-ride platform

The DH-RC.10 is the light-duty alternative offering a **level ride** from the vehicle floor to the ground (and vice versa), and **automatic tilt at ground level** .

While the half-dip ride lifts DH-RP are meant for the cost conscious fleet owners delivering small pallets or boxes and doing general freight and expediting, the level-ride DH-RC.10 (and heavier models) are better suited for **high stack cargo and rolling carts** .

The DH-RC.10 is designed for commercial vehicles up to 12T GVW. A special execution for refrigerated bodies is available as an option [OAP628].



**PLATFORM**

- Weight-saving full aluminium platform (base section + foldable point)
- The folding and unfolding of the platform are assisted by powerful torsion springs
- Synthetic rollers for the contact between the platform and the ground

**FUNCTIONAL & MECHANICAL CHARACTERISTICS**

- Conical / wedge platform. Level ride with automatic tilt at ground level

**HYDRAULICAL CHARACTERISTICS**

- 1 centrally mounted lift cylinder
- Electrical safety valves on all cylinders
- Manual emergency operation on all electrovalves
- Cylinder piston rods in hard-chromed stainless steel
- Cylinder(s) equipped with rubber gaitors
- Robust pump unit 12V or 24V DC mounted at the side of the lift frame

**ELECTRICAL CHARACTERISTICS**

- Exterior control box with main battery isolator switch and removable key [OAE030.BT.0]
- Electrical controls without sensitive electronic components
- Safe exterior controls with compulsory 2-hand operation
- Electric motor with thermal cut-out fuse

**FITTING**

- Bolt-on mounting plates for quick and easy fitting [OAM010]
- Narrow arm width for mounting between the chassis beams
- Integrated floor plate for flush mounting available as an option [OAM003 / 004]

**FINISH & MAINTENANCE**

- Low-maintenance bearings in all articulation points, plus grease nipples
- Lift frame in Protection PLUS finish (zinc phosphate + KTL epoxy primer + polyester powder top coat)
- Alu platform or platform sections in natural finish

Disclaimer: data and images of lifts and options are indicative, and may vary in function of the lift execution and vehicle details. Ask confirmation from DHOLLANDIA.



**TECHNICAL CHARACTERISTICS****DH-RC.10**

<b>Lift frame</b>	120 x 120 mm
<b>Cylinders</b>	1 lift cylinder + 2 fixed stabilisers
<b>Type of ride</b>	Wedged platform, level ride with automatic tilt at ground level
<b>Platform material</b>	Alu / Alu
<b>Standard platform depths</b>	1080 - 1280 mm
<b>Standard platform widths</b>	- 2000 - 2200 mm - Other widths on request [option OAP303]
<b>Lift arm lengths</b>	750 - 850 mm
<b>Lift arm widths</b>	550 mm
<b>Mounting</b>	- Rear floor plate [option OAM003] - Adapted for refrigerated floor [option OAP628]
<b>Standard control unit</b>	OAE030.BT
<b>Standard finish of the lift frame</b>	Protection PLUS [OAT102]

**MOUNTING DIMENSIONS****DH-RC.10**

<b>larm</b>	<b>750</b>	<b>850</b>
<b>K max.</b>	1180	1310
<b>K min. loaded</b>	900	1000
<b>C max.</b>	580	660
<b>C min.</b>	350	400
<b>CO max.</b>	600	650
<b>M</b> at C max.	810	895
<b>M</b> at C min.	980	1070
<b>V max.</b>	1080	1280





OAE001 - 2-button wander lead with spiral cable



OAE015.PR - 2 function toggle switch control (principal control)



OAE015.O - 2 function toggle switch control (option)



OAE030.BT.0 - Exterior joystick control box + main battery isolator switch (+ turn switch)



OAE041.BP.0 - Arctic push-button control box + main battery isolator switch (+ push button)

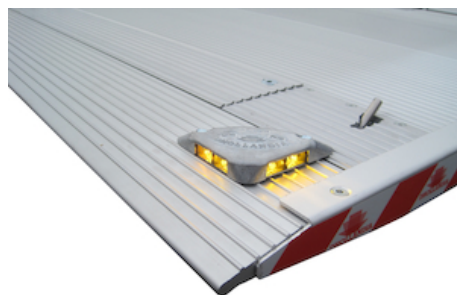

OAE200 - Flashing platform lights

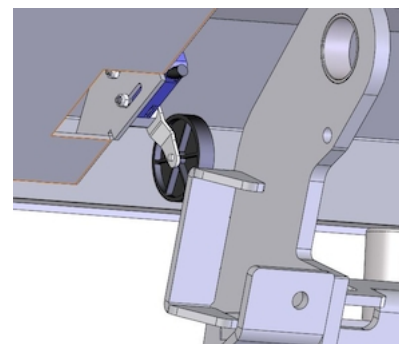

OAE205 - Limit switch + buffer DH-R\*

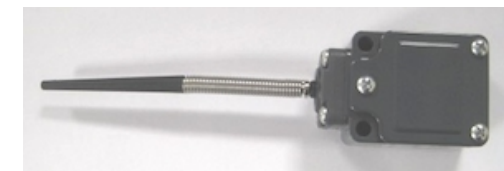

OAE213 - Limit switch E0387 (supplied loose)



OAE503.1 - Cabin switch (single use)



OAP100.M - 2-piece symm. roll-stops in the platform point - MANUAL

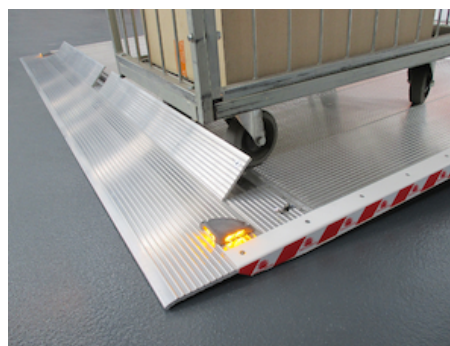

OAP100.A - 2-piece symm. roll-stops in the platform point - AUTOMATIC



OAP601 - Fixed part of folding platform in ALU instead of steel





Non-standard

OAP603 - Non-standard width for foldable platform



OAP620.C - Platform lock DH-RP with steel cable

OAP628 - Platform hands R... adapted for insulated floor



OAF130 - Round bumper tube mounted to the lift arms

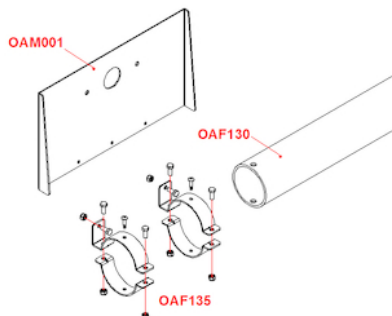

OAF135 - Brackets for light plates on bumper OAF130

OAM003 - Rear floor traverse RC10/RC20/RM20



OAT020 - Reflecting platform flags type TÜV



OAT023 - Reflecting platform flags type Export Red

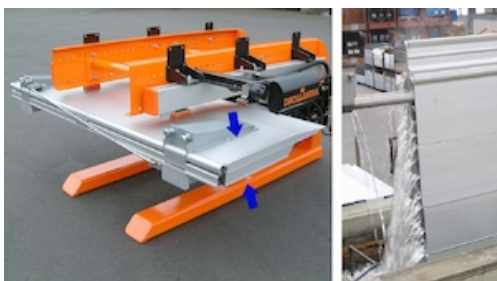

OAT136 - Anodisation alu base section + point DH-S and DH-R



OAU100 - Control box on L side (R steering wheel for UK)